





TREVI 1100



COM
VENTILAÇÃO
OPCIONAL



sem aro opcional



com aro opcional

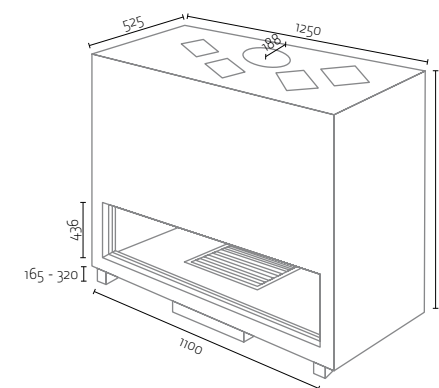

CARACTERÍSTICAS TREVI 1100

POTÊNCIA DE UTILIZAÇÃO (kW)	13,7 - 25,4
CONSUMO DE LENHA (kg/hora)	3,3 - 6,0
EMISSÕES DE CO (a 13% oxigênio)	0,51
EMISSÕES DE CO ₂ (%)	12,2
PESO (kg)	330
DIÂMETRO DA CHAMINÉ (em mm)	250
POTÊNCIA NOMINAL (kW)	19,5

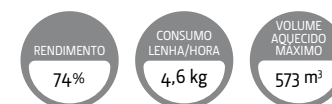

CLASSE DE EFICIÊNCIA

